

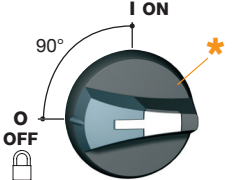

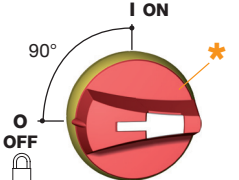
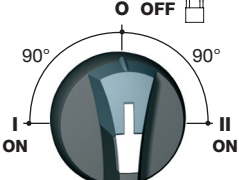
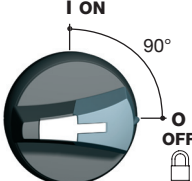
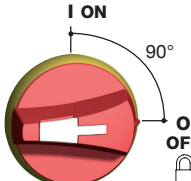
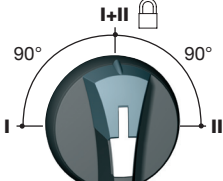
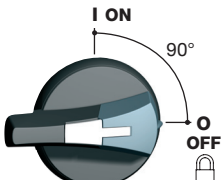
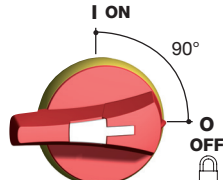
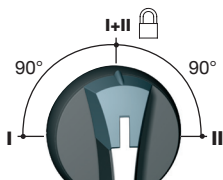
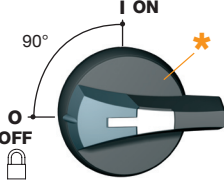
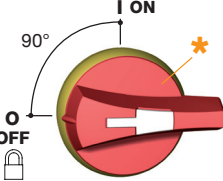
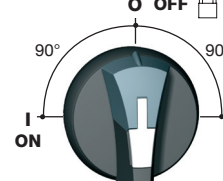
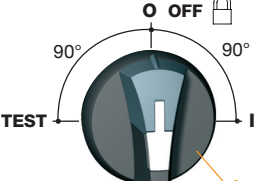
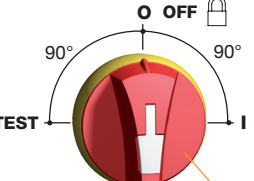
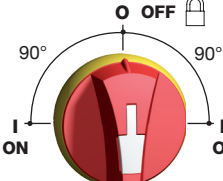

533746K

Edition 05/14 - IS 533746-K / RECTO-VERSO / S blanc offset quadri 80g/m²

 <p>14715111 / 14711111 14735111 / 14731111 147D5111 / 147D1111 14710111 / 14730111 147R0111 / 147R1111 147D0111</p>	 <p>14721111 14745111 / 14741111 147E5111 / 147E1111 14740111 / 147E0111</p>	 <p>14711113 14731113 / 147D1113 14730113</p>
 <p>147A5111</p>	 <p>147B5111</p>	 <p>14711114 14731114 / 147D1114 14730114</p>
 <p>148A5111 149A9111 148J5111 149J9111</p>	 <p>148B5111 149B9111 148K5111 149K9111</p>	 <p>14811114 / 14910114 14831114 / 148D1114 14930114 / 149D0114</p>
 <p>14815111 / 14811111 14835111 / 14831111 148D5111 / 148D1111 14919111 / 14910111 14939111 / 14930111 149D9111 / 149D0111</p>	 <p>14845111 / 14841111 14949111 / 14940111 148E5111 / 148E1111 149E9111 / 149E0111</p>	 <p>14831113 / 148D1113 14930113 / 149D0113 14811113 / 14910113 14835113 / 148D5113 14939113 / 149D9113</p>
 <p>149D9115 / 149D0115</p>	 <p>149E9115 / 149E0115</p>	 <p>148E5113 / 148E1113 14845113 / 14841113 14949113 / 14940113 149E9113 / 149E0113</p>

Modification of the handle to allow padlocking in all positions.
Modification de la poignée afin de pouvoir cadenasser dans toutes les positions.
Modificación de la mandel para obtener la función de cerrar con candado de las posición I y/o II, 0 standard.
 通过手柄更改可允许挂锁在任何位置。

**TO REMOVE
DEMONTAGE
拆卸**



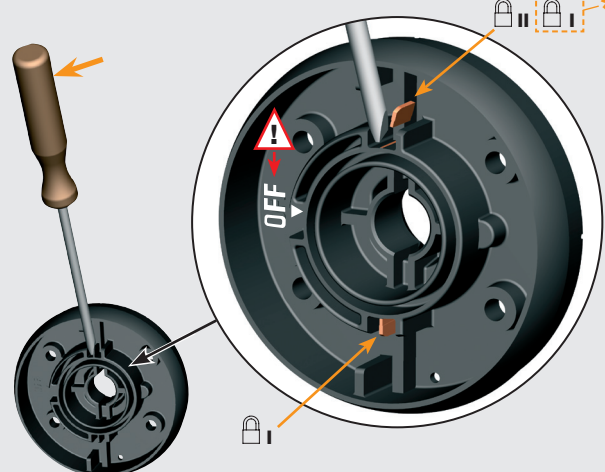

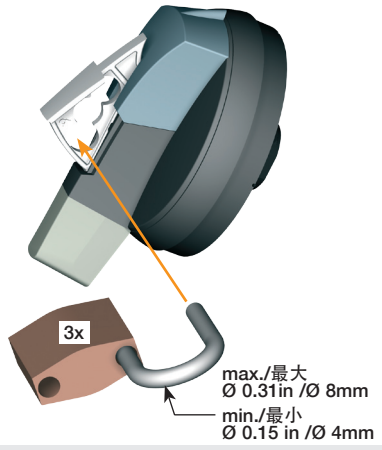

max./最大
 \varnothing 0.31 in / \varnothing 8mm
 min./最小
 \varnothing 0.15 in / \varnothing 4mm

⚠ DANGER / PELIGRO / 危险

HAZARDOUS VOLTAGE. This equipment must be installed and serviced only by qualified electrical personnel. Turn off all power supplying this equipment before working on or inside equipment. Always use a properly rated voltage sensing device to confirm power is off. Replace all devices, doors, and covers before turning on power to this equipment. **Failure to follow these instructions will result in death or serious injury.**

TENSION DANGEREUSE. L'installation et l'entretien de cet appareil ne doivent être effectués que par du personnel qualifié. Coupez l'alimentation de cet appareil avant d'y travailler. Utilisez toujours un dispositif de détection de tension à valeur nominale approprié pour confirmer que toute alimentation est coupée. Remplacez tous les dispositifs, les portes et les couvercles avant de mettre cet appareil sous tension. **Si ces précautions ne sont pas respectées, cela entraînera la mort ou des blessures graves.**

TENSION PELIGROSA. Solamente el personal de mantenimiento eléctrico especializado deberá instalar y prestar servicios de mantenimiento a este equipo. Desenergice el equipo antes de realizar cualquier trabajo en él. Siempre utilice un dispositivo detector de tensión adecuado para confirmar la desenergización del equipo. Vuelva a colocar todos los dispositivos, las puertas y las cubiertas antes de energizar este equipo. **El incumplimiento de estas precauciones podrá causar la muerte o lesiones serias.**

危险电压。 这类装置必须只由专业人员进行安装和维修，在电气装置上或内部进行操作前必须关掉所有外供电源。使用合适的额定电压测量装置来确认电源已经关掉。在电气装置通电前必须重新放好所有的部件，柜门和开关盖。不遵守以上预警将导致严重伤害或死亡。

For/用于 IP55

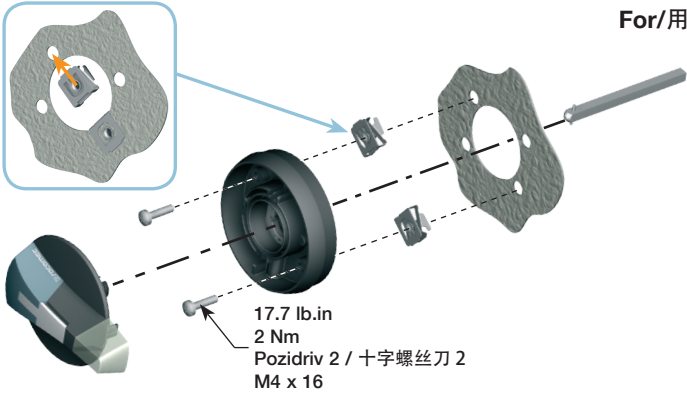

17.7 lb.in
2 Nm
Pozidriv 2 / 十字螺丝刀 2
M4 x 16

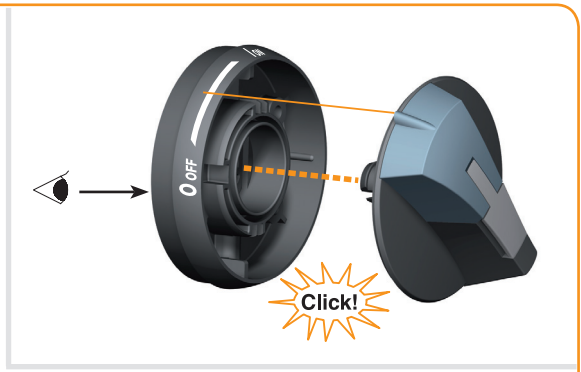

Click!

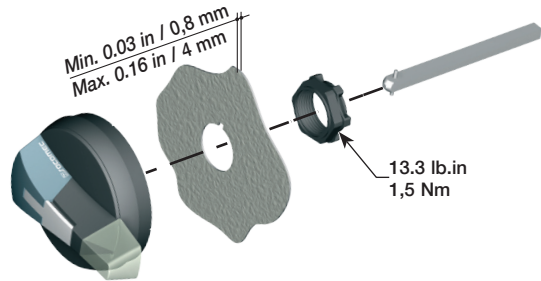

Min. 0.03 in / 0.8 mm
Max. 0.16 in / 4 mm

13.3 lb.in
1.5 Nm

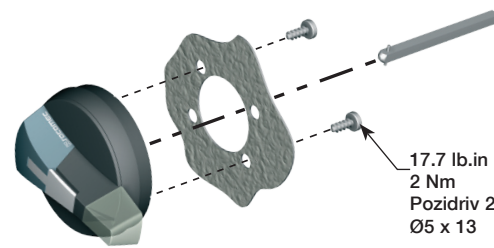

17.7 lb.in
2 Nm
Pozidriv 2 / 十字螺丝刀 2
Ø5 x 13

For/用于 IP65, Type/类型 3R,12 and/和 4,4X

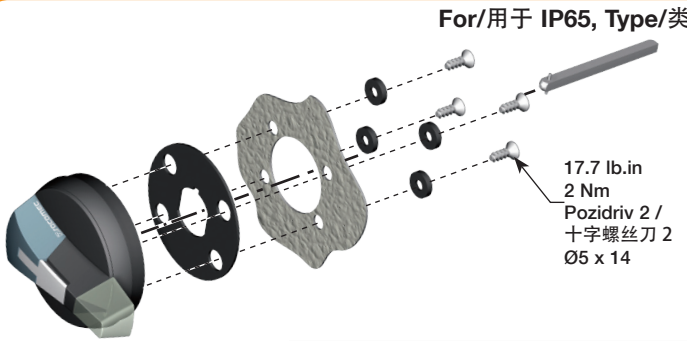

17.7 lb.in
2 Nm
Pozidriv 2 / 十字螺丝刀 2
Ø5 x 14

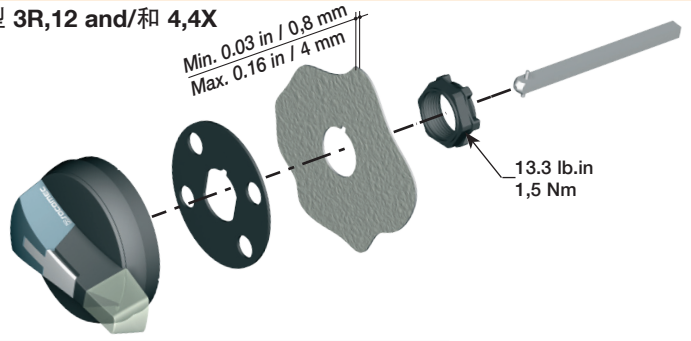

Min. 0.03 in / 0.8 mm
Max. 0.16 in / 4 mm

13.3 lb.in
1.5 Nm

Fusible disconnect switches : see instruction sheet 533279 / 熔断器组合开关: 见说明书533279

SIRCO M SIRCOVER M
14070532: L = 12,6 in / 320 mm

SIRCO MV
14090632: L = 12,6 in / 320 mm

USE / UTILISER
使用

14190000

For/用于 IP55, IP65,
Type/类型 3R,12
and/和 4,4X

35.4 lb.in
4 Nm

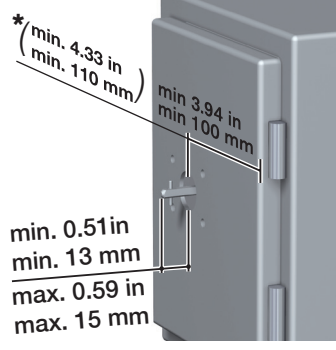
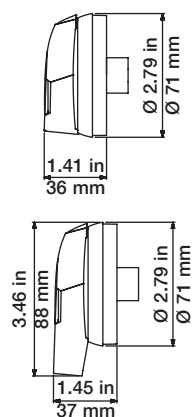

* Only for / 仅用于 { 14710111, 14730111, 14740111
14730113, 14730114

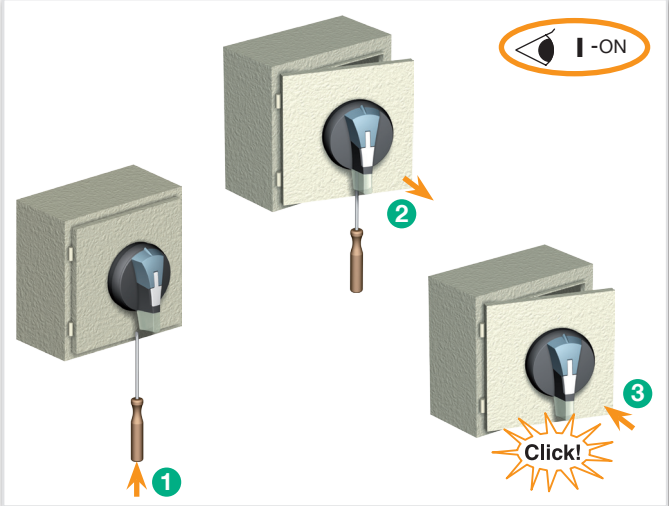
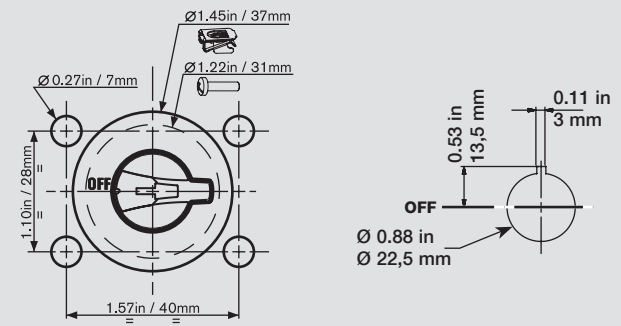

⚠ DANGER / PELIGRO / 危险

HAZARDOUS VOLTAGE. Disconnect all power before servicing. Be sure enclosure is closed securely before operating device. Testing of live equipment should only be performed by qualified service personnel in accordance with local regulations. **Failure to follow these instructions will result in death or serious injury.**

TENSION DANGEREUSE. Couper l'alimentation avant intervention. S'assurer de la fermeture du coffret avant manoeuvre de l'appareil. Les essais des équipements sous tensions ne doivent être effectués que par du personnel qualifié. **Si ces précautions ne sont pas respectées, cela entrainera la mort ou des blessures graves.**

TENSION PELIGROSA. Desenergice el equipo antes de una itervención. Asegurarse del cierre de la caja antes de manipular el equipo. Solamente el personal especializado deberá probar los equipos sobre tension. **El incumplimiento de estas precauciones podrá causar la muerte o lesiones serias.**

危险电压。检修前必须关掉所有外供电源。开关操作前确认柜门已关好。必须只由专业人员进行设备的带电检测。不遵守以上预警将导致严重伤害或死亡。